

10 Pivot Adjustment Range

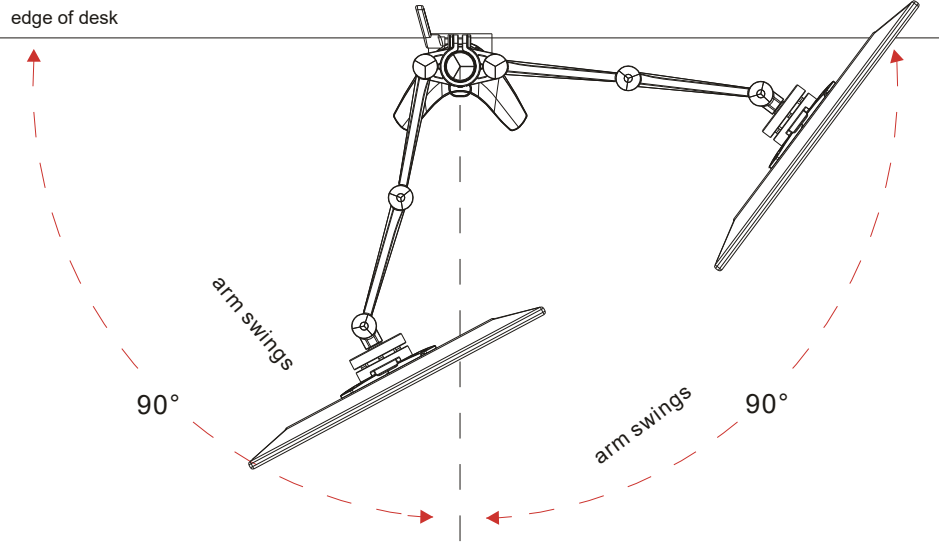

WARNING









- Swinging the arm beyond the suggested range may result in the mount slipping off the desk and causing serious personal injury or property damage.

Maintenance

Please check that the desk mount is secure and safe to use at regular intervals. If you have any questions regarding any of the instructions or warnings; please contact your local distributor directly (OR) contact QualGear technical support via email at support@qualgear.com.

Scan the QR Code™ below to contact us:



- | | |
|---|---|
|  +1 (972) 423-8960 |  support@qualgear.com |
|  facebook.com/qualgear |  youtube.com/qualgear |
|  twitter.com/qualgear |  store.qualgear.com |
|  pinterest.com/qualgearusa |  google.com/+qualgear |

QualGear
Accessories that Inspire.

QG-DM-02-016
INSTALLATION MANUAL

DUAL MONITOR DESK MOUNT

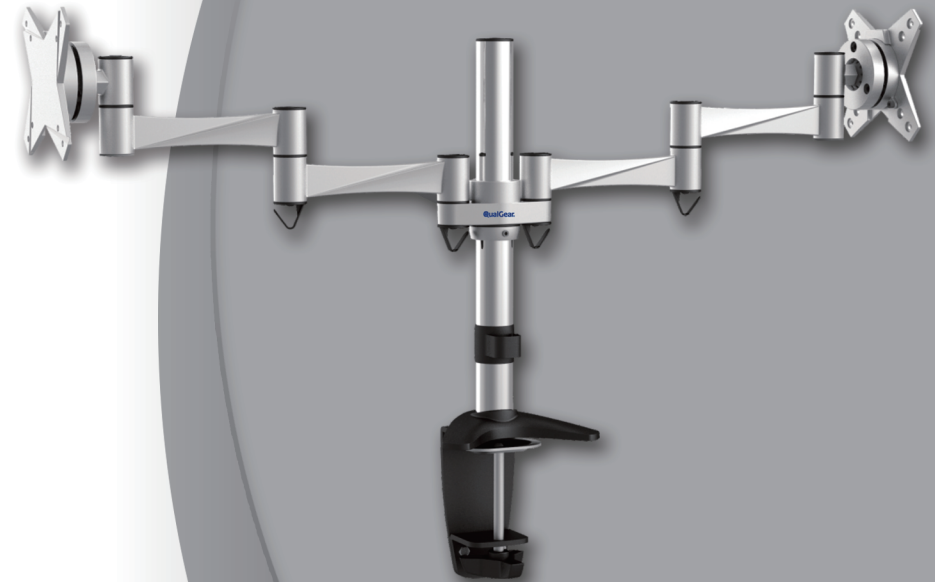

27"
MAX

For Most 13" to 27" Flat Screen Monitors and TVs

8kgx2
(17.6lbs)x2
RATED

CAUTION!
Do not exceed the maximum rated weight specified. Otherwise, serious injury or property damage may occur.



VESA

75x75 | 100x100

Scan the QR Code™ below for more info about this product:



■ 1 Year Limited Warranty

■ Version October 2017

NOTE Please read the entire installation manual before you start installation and assembly.

WARNING

- Do not begin the installation of this product before you have read and understood all the instructions and warnings contained in this installation manual. If you have any questions regarding the instructions, please contact the reseller or QualGear support department via email at support@qualgear.com.
- This mounting bracket was designed to be installed and utilized **ONLY** as specified in this manual. Improper installation of this product may cause damage or serious injury.
- Make sure that the supporting surface will safely support the combined weight of the equipment and all attached hardware and components.
- This product should only be installed by someone, who has good mechanical ability with prior experience in installation and assembly of products and fully understands this manual.
- Always use an assistant or mechanical lifting equipment to safely lift and position the equipment.
- Tighten screws firmly, but do not over tighten. Over tightening can cause damage to the items. This greatly reduces their holding power.
- All QualGear products are intended for indoor use only and any outdoor use voids the limited warranty.
- All QualGear products are designed and tested for residential use only and any commercial use voids the limited warranty. For warranty information, please visit qualgear.com/warranty.php.

Parts Checklist

! **IMPORTANT:** Before starting installation, please check that all parts shown in this checklist are included. If any parts are missing or damaged, contact your local distributor or support@qualgear.com for replacement parts and do not start assembly and installation until you receive all the parts.

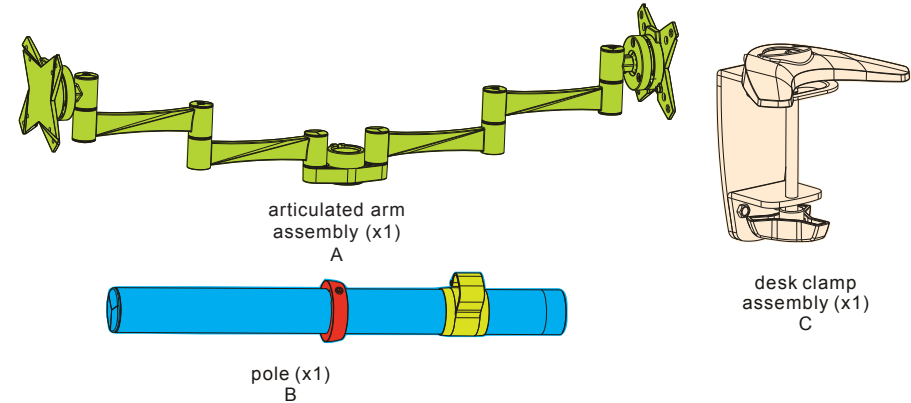

Hardware Package

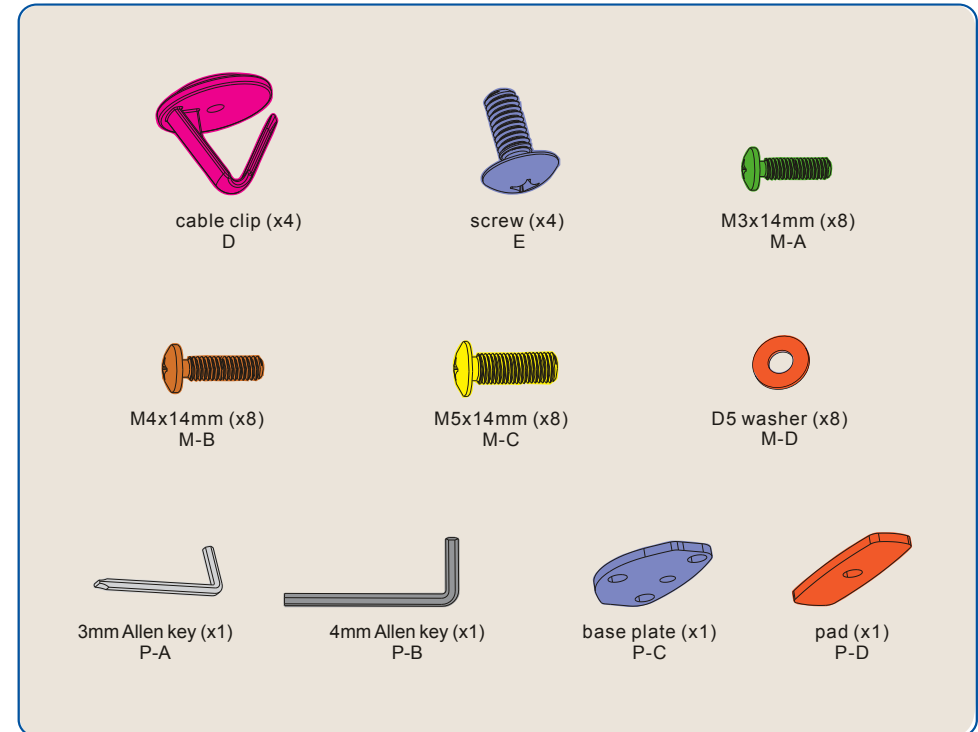

1 Installing the Cable Clip

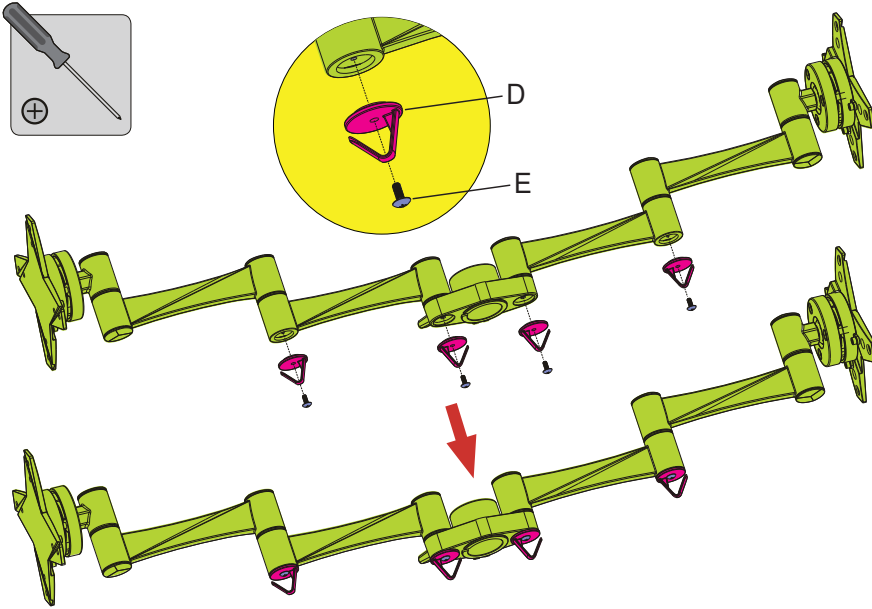

Install cable clips with the provided screws using a Philips screwdriver.

2 Removing the VESA Plate

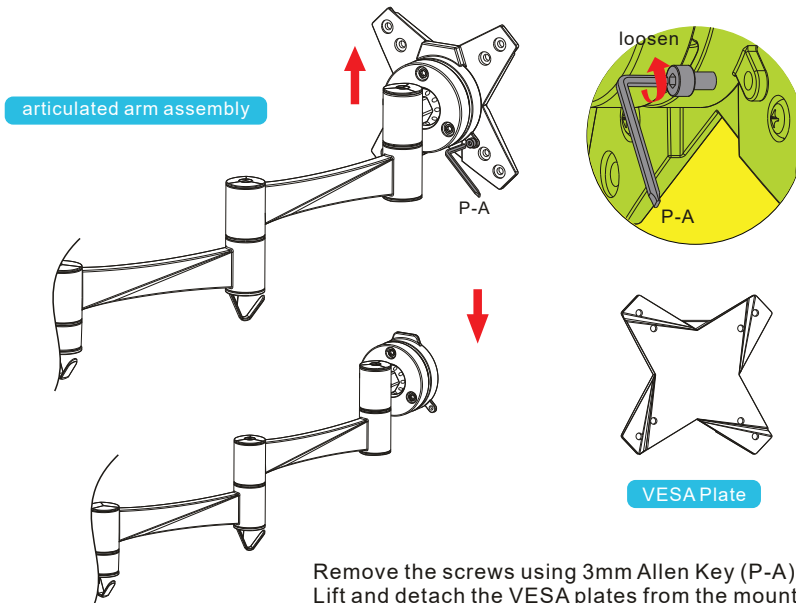

Remove the screws using 3mm Allen Key (P-A). Lift and detach the VESA plates from the mount.

3 Assembling the Pole and Desk Clamp

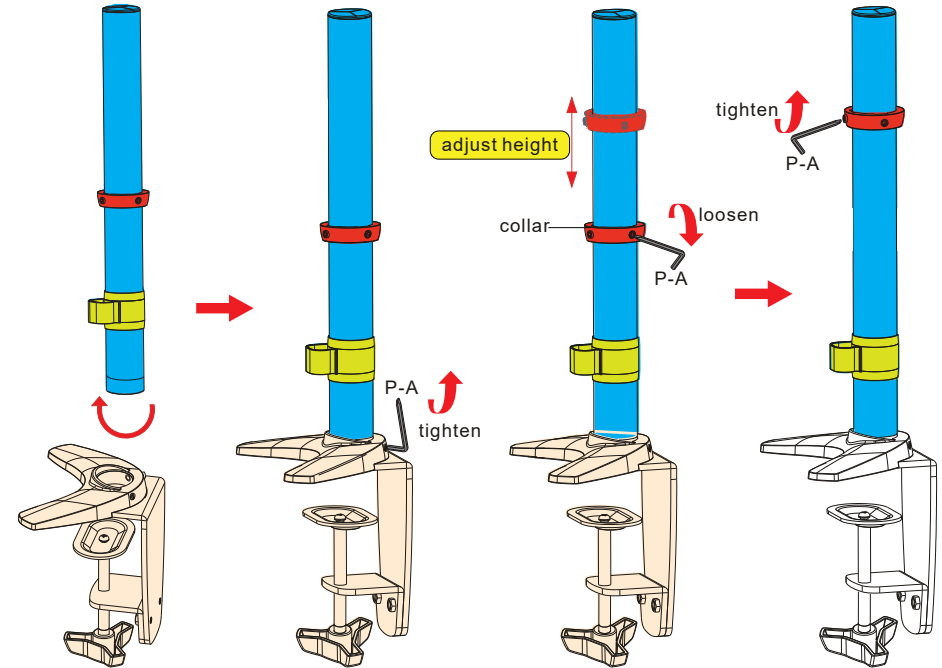

Insert the pole (B) into the desk clamp (C) and tighten the screws using 3mm Allen Key (P-A). To adjust monitor height, first loosen collar screws using 3mm Allen Key (P-A), then set the collar at a desired position and tighten the collar screws using 3mm Allen Key (P-A).

4a Edge Installation

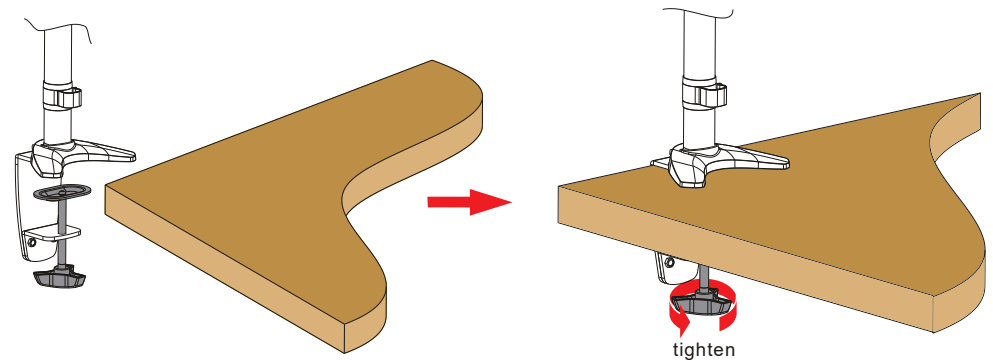

Turn the knob to make clamp fit to desk edge, then secure it tightly.

NOTE Min. desktop thickness=10mm(0.39")
Max. desktop thickness=90mm(3.54")

4b Grommet Installation

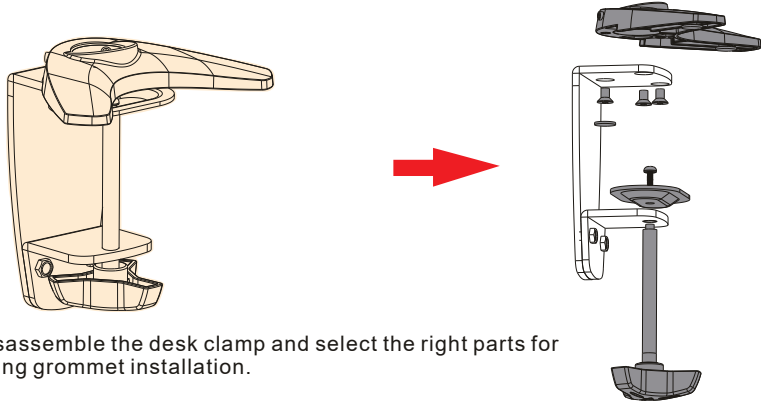

Disassemble the desk clamp and select the right parts for using grommet installation.

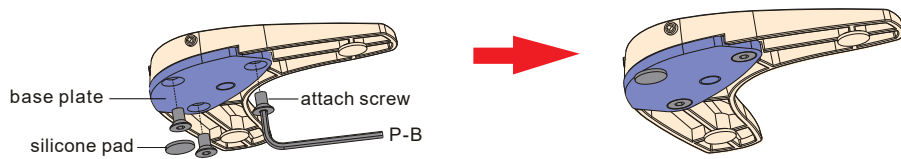

Re-install the base plate with the three retained screws, and then tighten securely using a 4mm Allen Key (P-B). Then attach silicone pad for each screw.

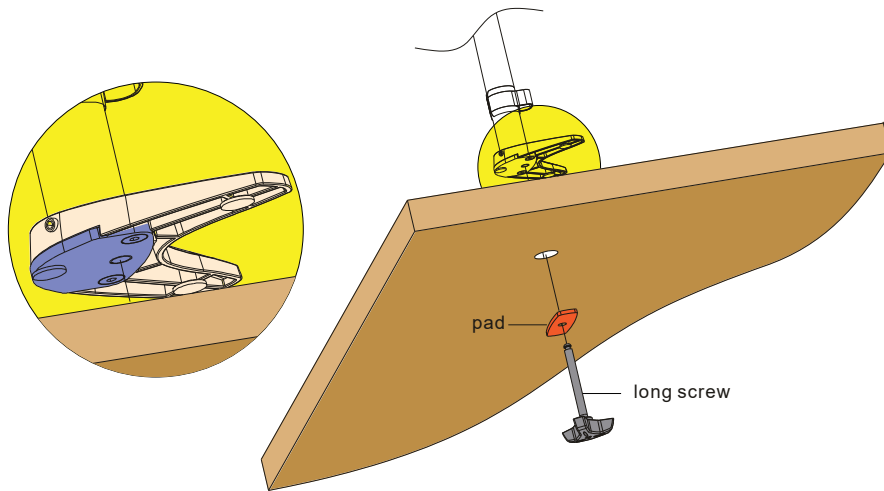

Insert the long screw into the base plate through the hole and pad (P-D) as shown above. Then tighten the long screw to hold the mount securely.

NOTE Min. hole diameter = 10mm(0.39")
Max. hole diameter = 70mm(2.76")

5 Installing the Articulated Arm Assembly

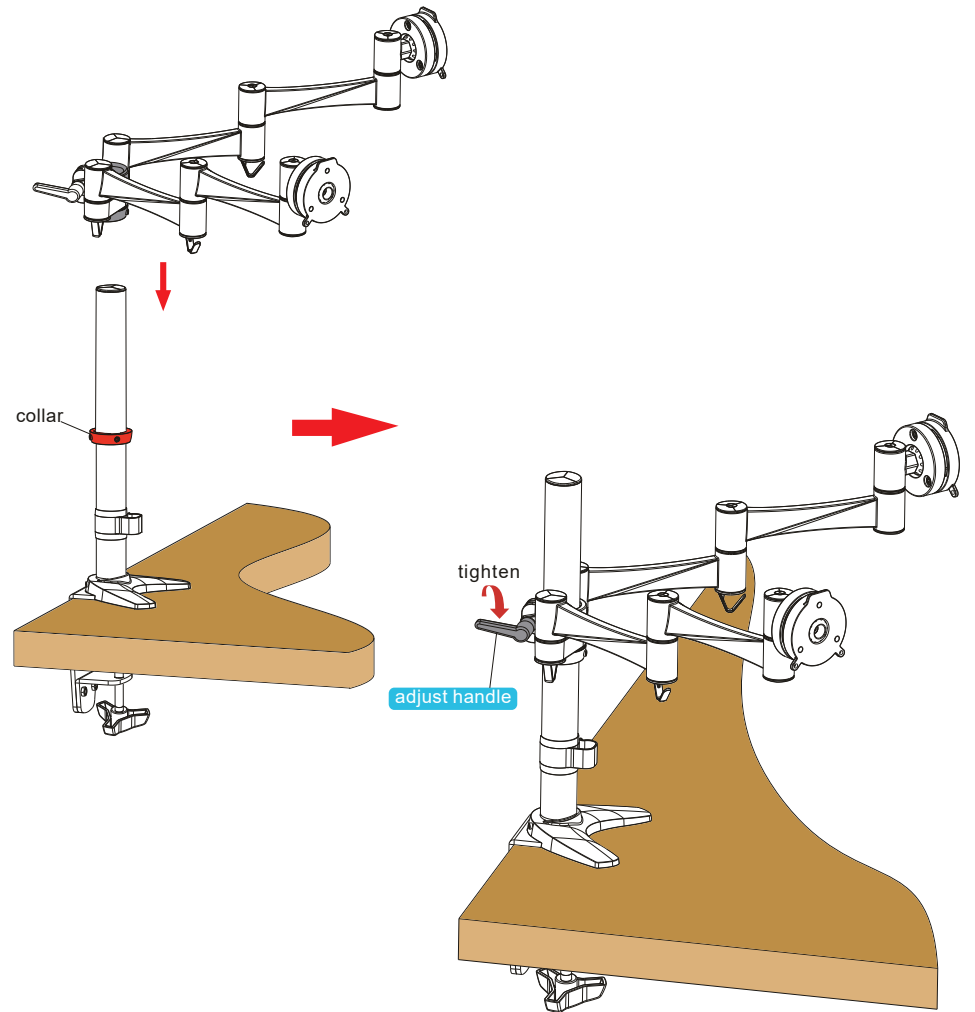

Insert the articulated arm assembly into the pole until it touches the collar. Then tighten the adjust handle.

NOTE Plastic handle can be pulled out due to limited amount of space.

WARNING

- Tighten all screws but do not over tighten.

6 Installing the VESA Plate

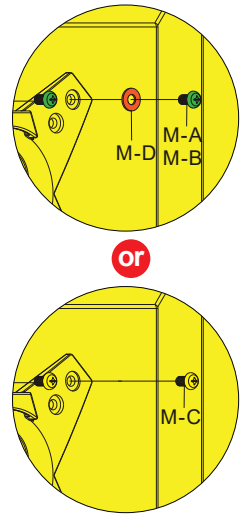
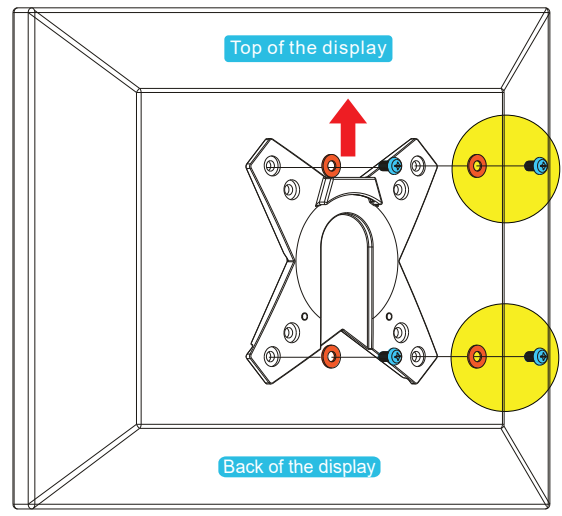
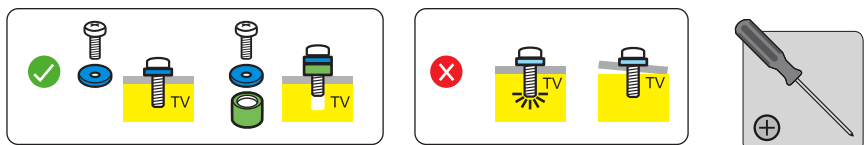
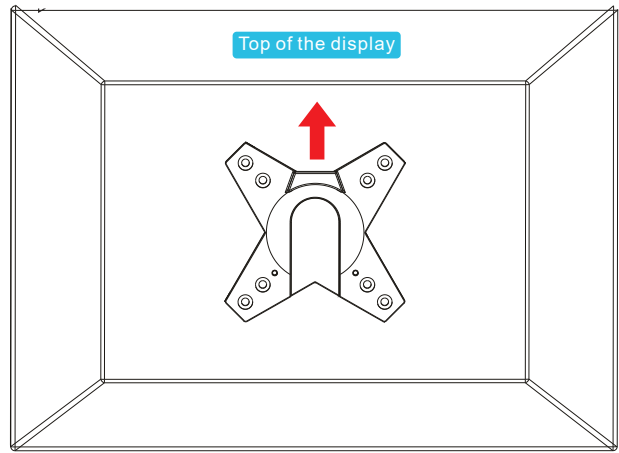

Choose appropriate screws and washers according to the type of your display, attach the VESA plate to the back of the display and tighten the screws using a Philips screwdriver.

⚠ WARNING

- Tighten all screws at this time but do not over tighten.

7 Attaching the Display

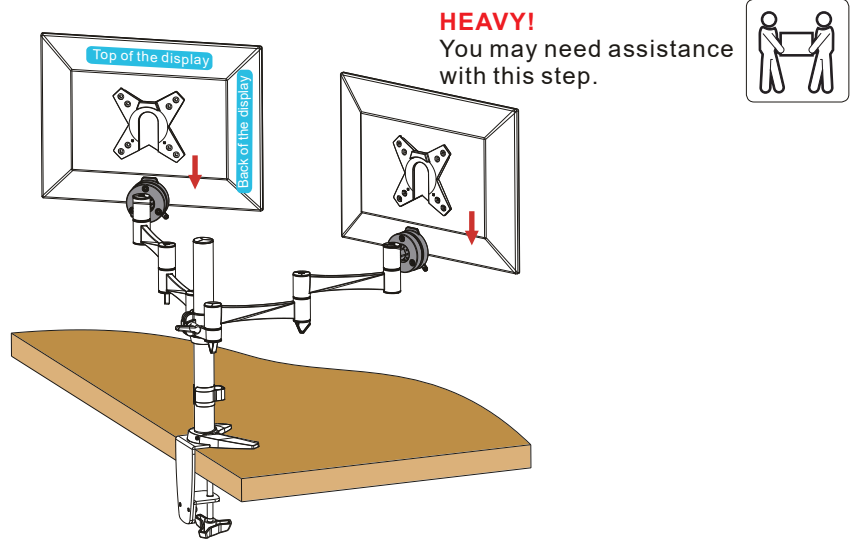

Lift your display and guide the screws into the mounting holes on the mount

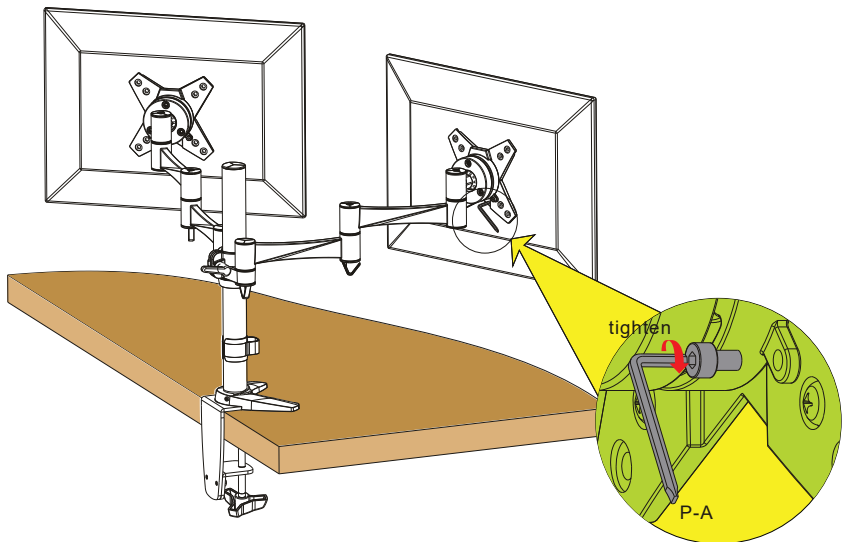

Attach the VESA plate to the mount with the retained screws from Step #2 (see page 3) and tighten them using a 3mm Allen Key (P-A).

NOTE Ensure the display is held securely until all screws are firmly installed

8 Cable Management

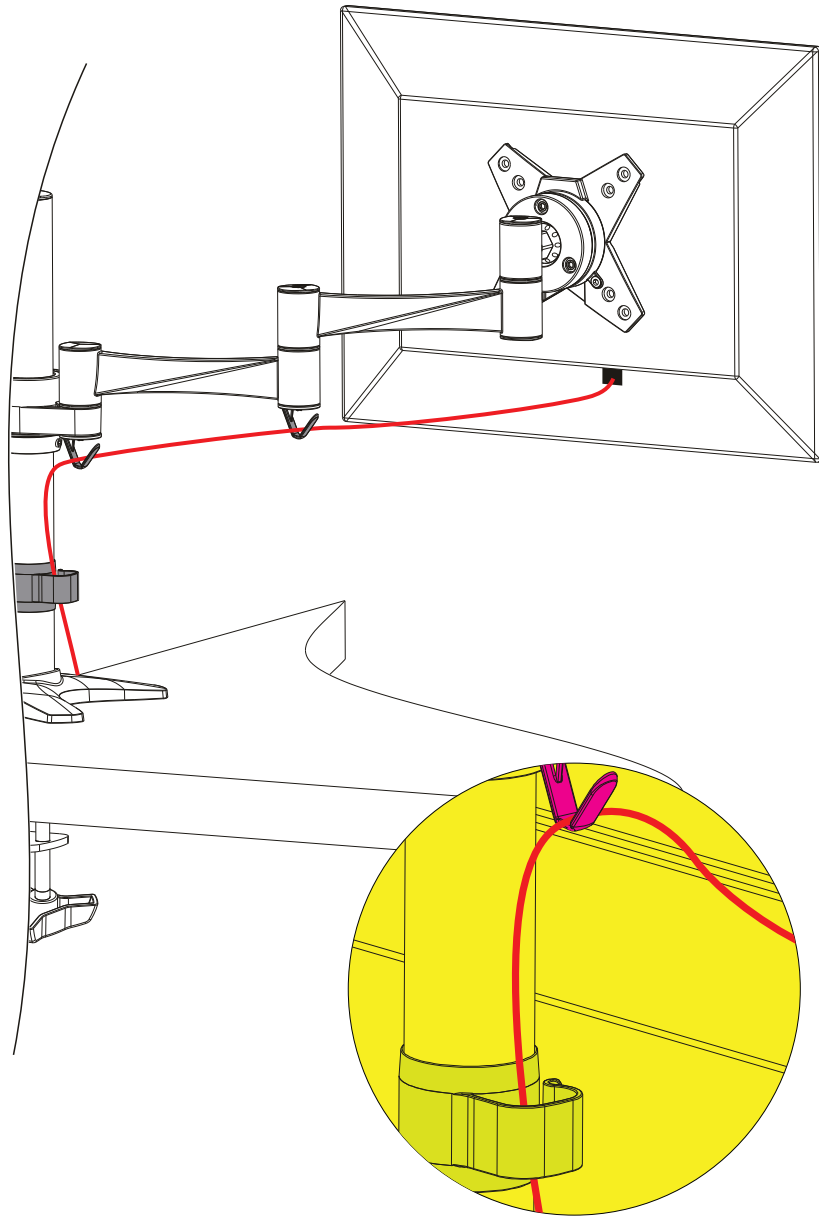

NOTE Leave slack in the cables for cantilever arm movement.

Connect cables to your display and route through the cable clip and along the arms.

9 Adjustments

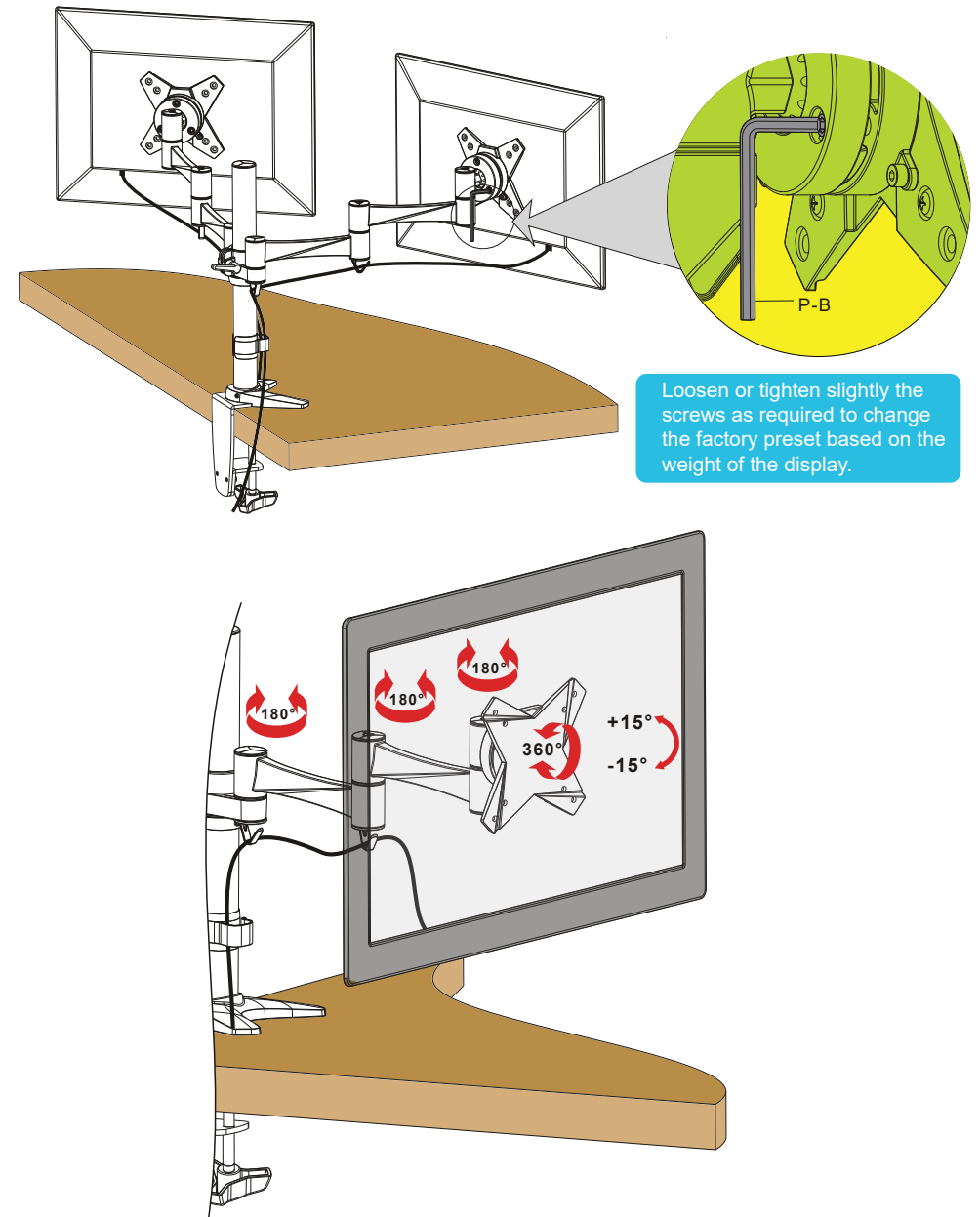

Loosen or tighten slightly the screws as required to change the factory preset based on the weight of the display.

The display can be adjusted to the desired position by tilt and swivel the bracket.